

Technology Update Efficient Infrastructure Design

Kedington

....The KEY network element

**Data Centre/Server Room
Design Considerations**

Contents

1. Energy efficiency

- PUE
- Opportunities to maximize efficiency

2. Configuration/Design/layout

- Hot aisle/Cold Aisle
- Water Cooling
- Passive Cabinet cooling
- Power Management
- Consequence of Convergence
- Pre-terminated cables
- Standards

The design and build directly impacts the overall efficiency and Total Cost of Ownership (TCO).

Data Centre - General Energy Metric

Power Usage Efficiency (PUE)

$$\text{PUE} = \frac{\text{Total Facility Power}}{\text{IT Equipment Power}}$$



Ideal score = 1 (impossible)

Current Best Practice = <1.5

Lower PUE => Lower Cost

Smaller Carbon Footprint!!!

Energy Consumption



Typical Data Room Power Breakdown

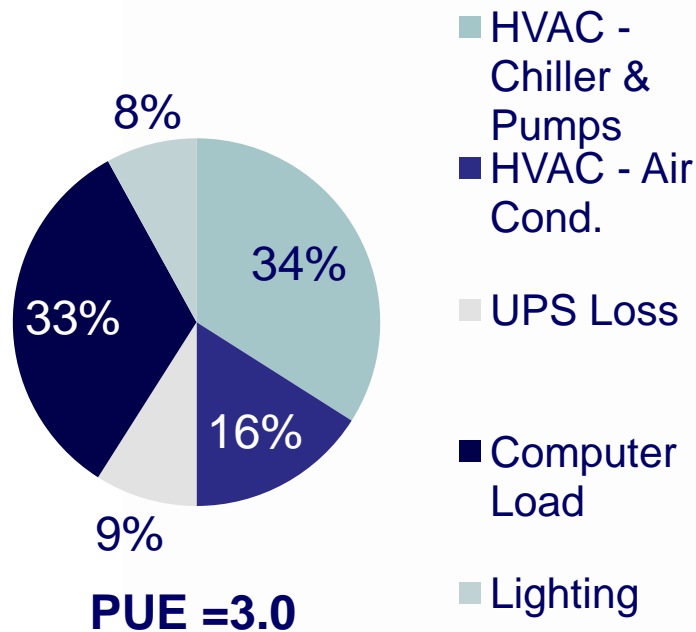

Efficiency Opportunities

- Virtualisation
- Processor efficiency
- Workflow analysis
- **Cooling**

The Savings @ 30 Kw IT Load

PUE = 3.0 => 90 KW consumpt.

PUE = 1.5 => 45 KW consumpt.

Saving = 45 KW

€39,420 per annum (10 cent/KWh)

Thermal Management Trends



	2000	2006	2012
Typical Full Cabinet	2-4 kW	8-16 kW	10-25 kW
High-End Server	<1 kW	4 kW	5 kW
Extreme Density Switch	2 kW	7 kW	9 kW

Heat loads in data centers are rising.....

Hot Aisle / Cold Aisle Cabinet Layout

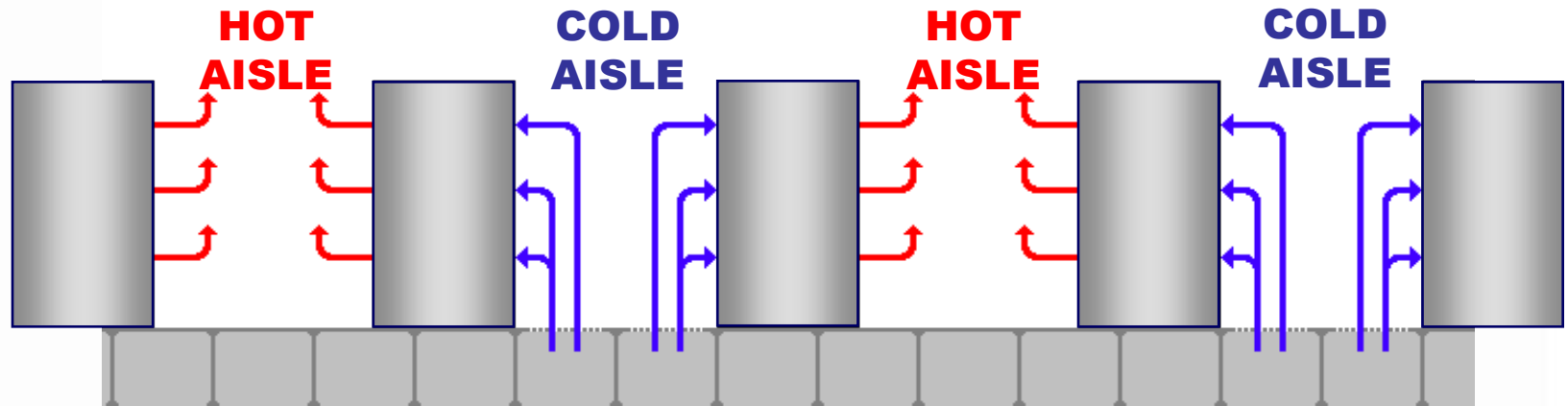

- Fronts face fronts; backs face backs
- Open floor tiles in cold aisle; no open floor tiles in hot aisle
- Seal all floor tile cable access cut-outs
- Air delivery satisfies air consumption

Cabinet Features for Hot/Cold Aisle

- Perforated Metal Doors – Front and Rear
- Internal Air Dams – to prevent recirculation

BAD

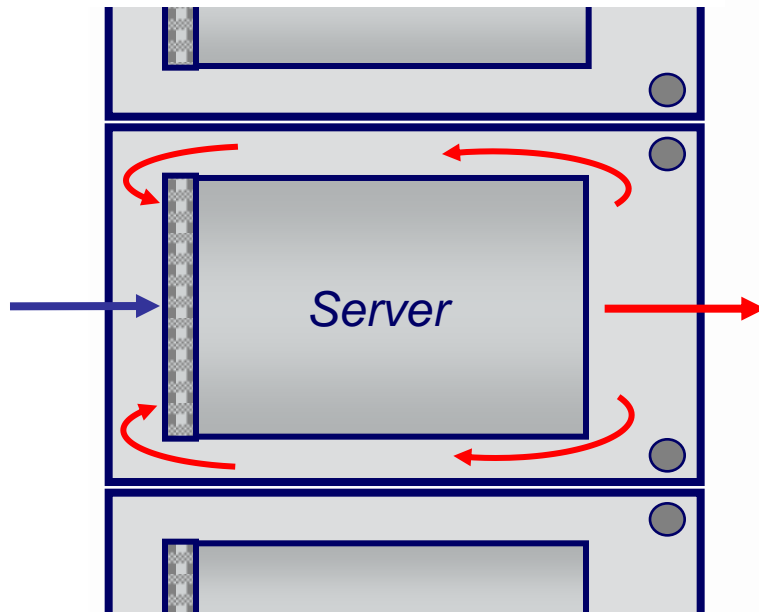

GOOD

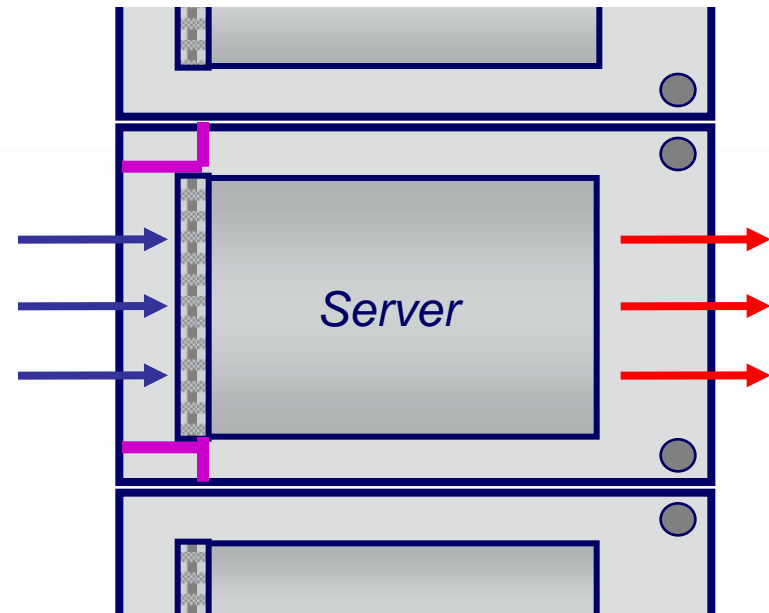

Hot Aisle / Cold Aisle Layout

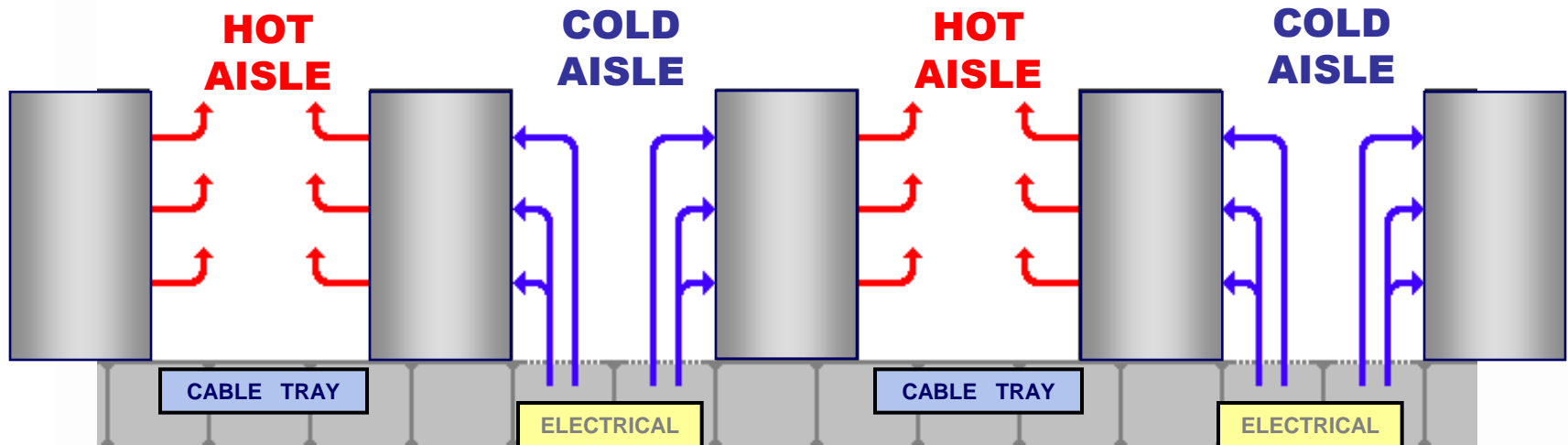

- Data cable tray should run down hot aisle
- Power cables and conduit should be near the floor and in the cold aisle
- If possible , consider keeping under floor empty, run cables above cabinets.

Cabinet Features for Hot/Cold Aisle

- Use filler panels – to prevent recirculation
- Prevent bypass airflow

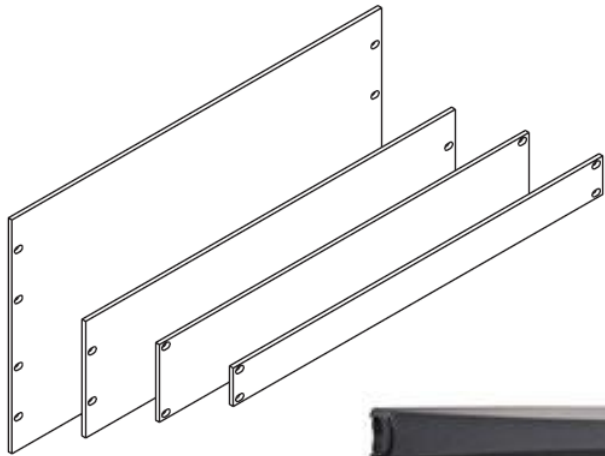

Bypass
Airflow

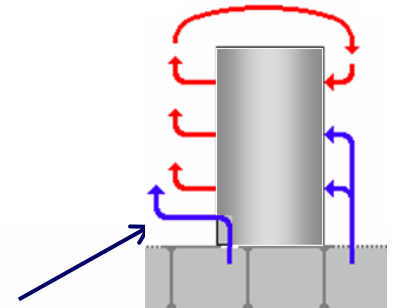

Enclosed Aisle

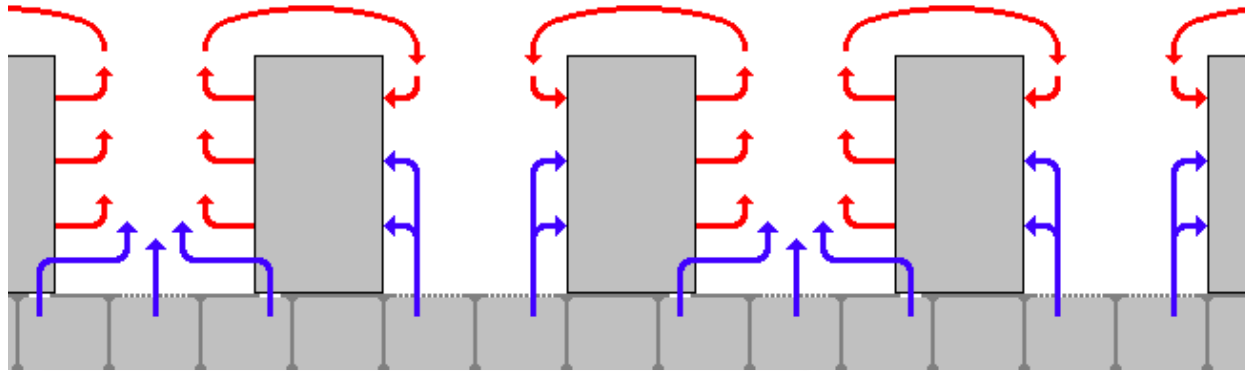

- Air mixing
- Hot Spots



- Active Cocooning
- Passive Cocooning

Aisle-Cocooning System



Dramatically lowers the cold air temperature available to the servers.

Ensures consistent intake air temperature to each server.

Reduces the load on the computer room air conditioning.

Saves Energy



Potential Next Generation Cabinets

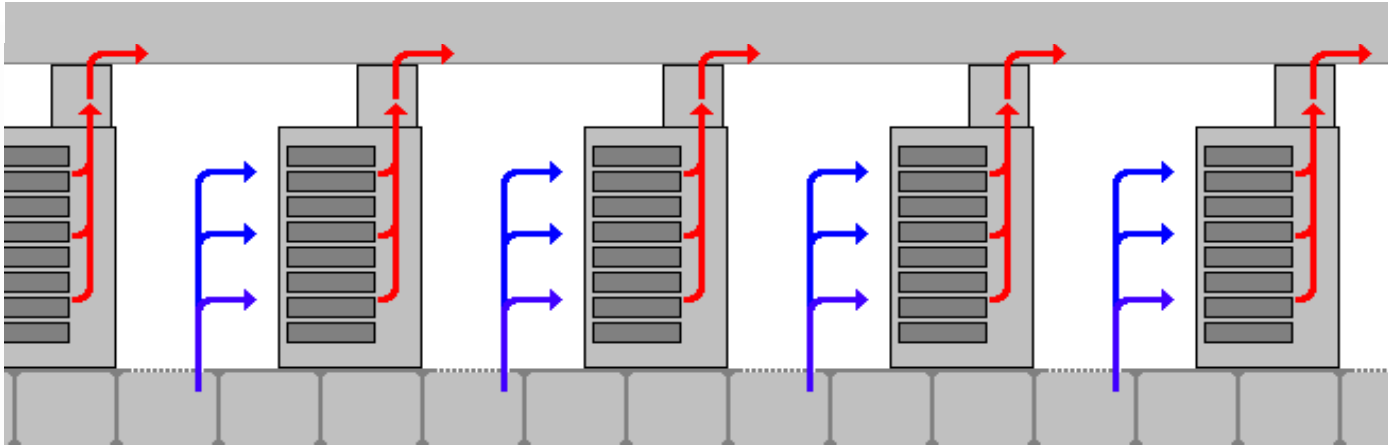

- Hot air is physically segregated from cold air in return air duct
- Rear door is “sealed” to prevent exhaust air from leaking into room
- Air Dams in front of cabinet prevent air recirculation inside cabinet`
- Room A/C is easy to manage, with little regard to concentrated heat loads
- Cabinets can be placed and oriented any way desired
- Cold air delivery can be shared throughout room without “zone” issues

Chimney Exhaust Cabinets



Passive Air Cooled Cabinets

Cold Aisle

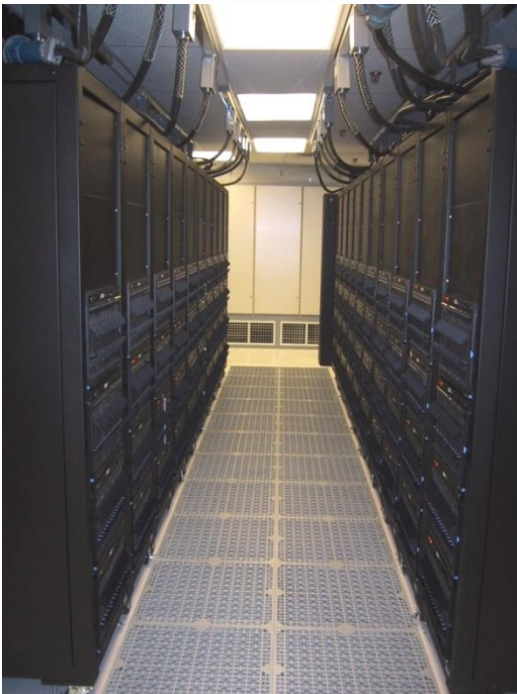

“Hot Aisle”



- Cabinet direction not critical.
- False Floor not mandatory.
- Tested to 25Kw per cabinet.
- High temp PDU/KVM required.
- False ceiling not essential but will add to efficiency.
- When used with “Free Cooling” PUE of <1.2 is possible.

Cable Placement and Thermal Management



- For every 10°C increase above 21°C, the mean time to failure (MTTF) for active equipment is reduced by 50%!
- The average large data centre provides 2.7 times more cooling than necessary due to poor airflow management in racks and cabinets
- In most data centres 60% of conditioned airflow bypasses the computer equipment air intakes.
- Cabling issues are consistently ranked as the #1 contributor to poor cooling in the data centre.



Cable Placement: Under-floor or Overhead?



Advantages

- Clean appearance
- Improved security

Disadvantages

- May impede cooling airflow
- More difficult to maintain and upgrade



Advantages

- Simpler maintenance and upgrade
- Will not affect underfloor cooling

Disadvantages

- Appearance
- Decreased security (cables exposed)

Water Cooled Cabinets

Water is 3467 times more efficient than air in removing heat!

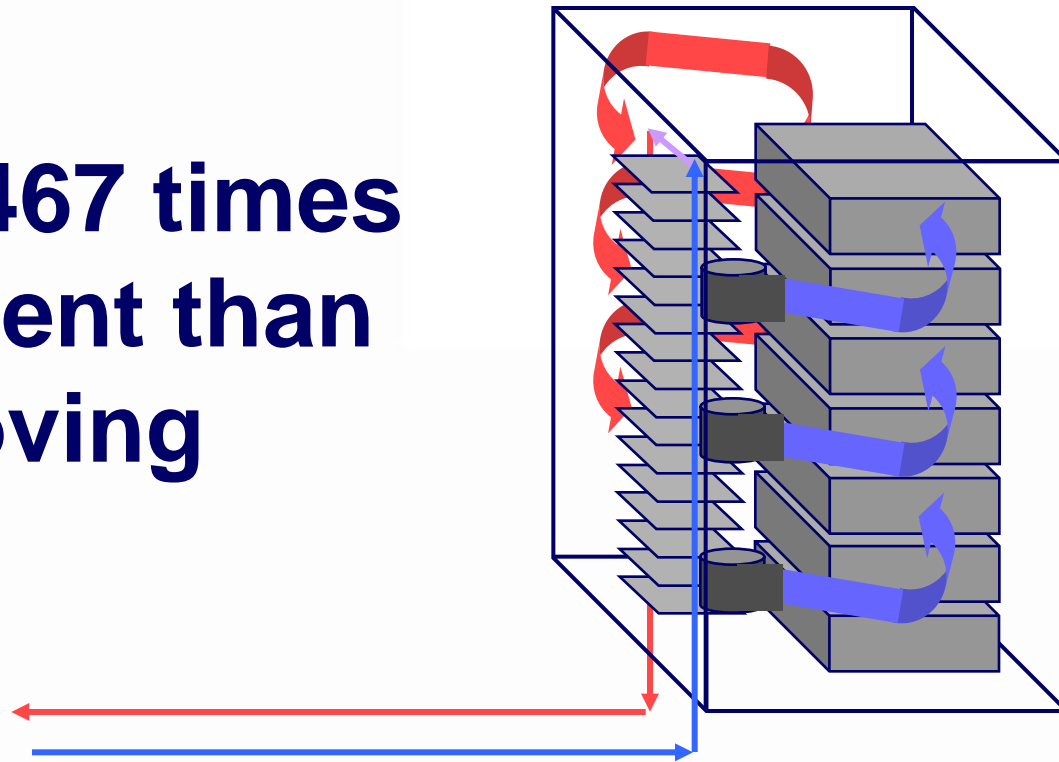

Water Cooled Cabinets

- **Benefits**
 - Cooling at the cabinet
 - Can be scaled at each cabinet for specific load
 - Doesn't require air distribution under a raised floor
- **Complicated**
 - Coolant lines running throughout the data center
 - Multiplies the possible points of failure in the data center
 - Requires a rethinking of how we design for redundancy
- **Costly - & increased cabinet size.**

Power Management



PM 3000 / PM2000 Horizontal



PM 3000 / PM2000 Vertical

Extensive Power Management features

- Outlet level switching and metering
- Web / Serial Management with data logging
- DSView3 Integration : One single interface for IT Managers

Technology Convergence

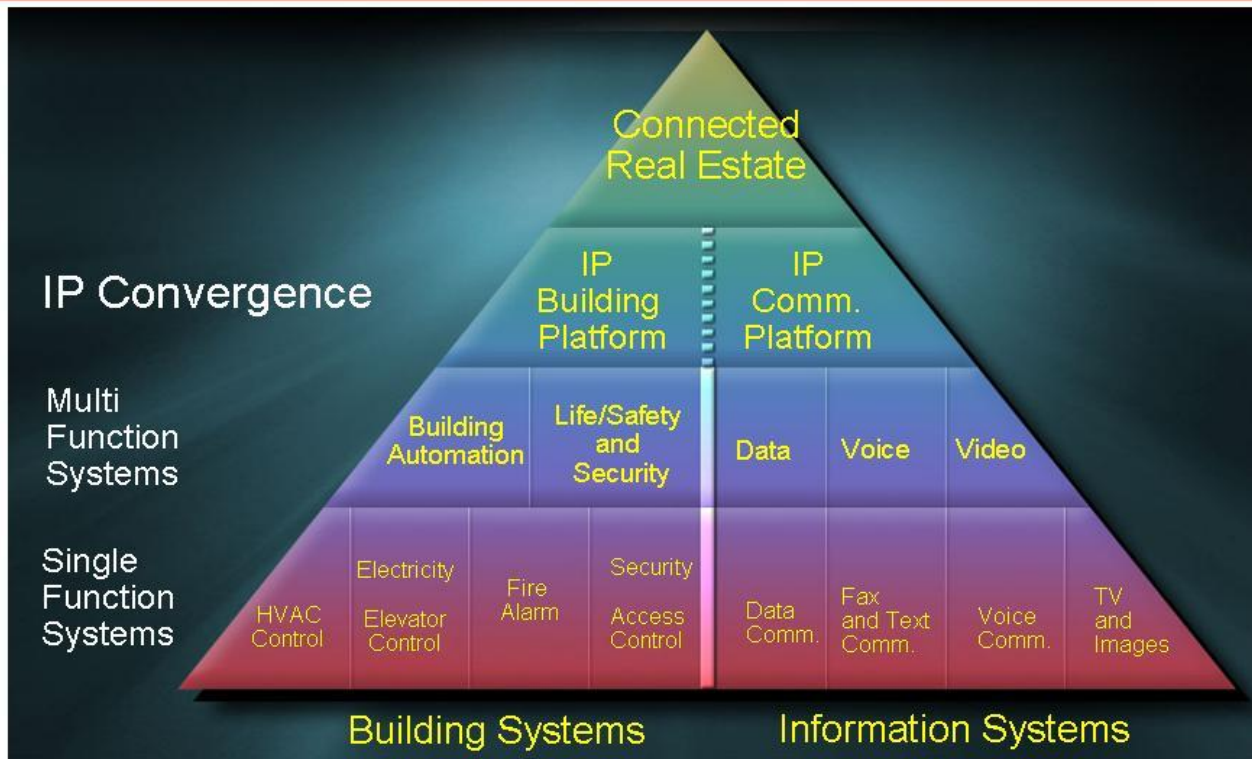

Source: Interoperable Integration Between BAS Systems and IP Based Access Control and CCTV, Novus Edge, ISC West 2007

Data Centre Design

-Layout For Converged Networks

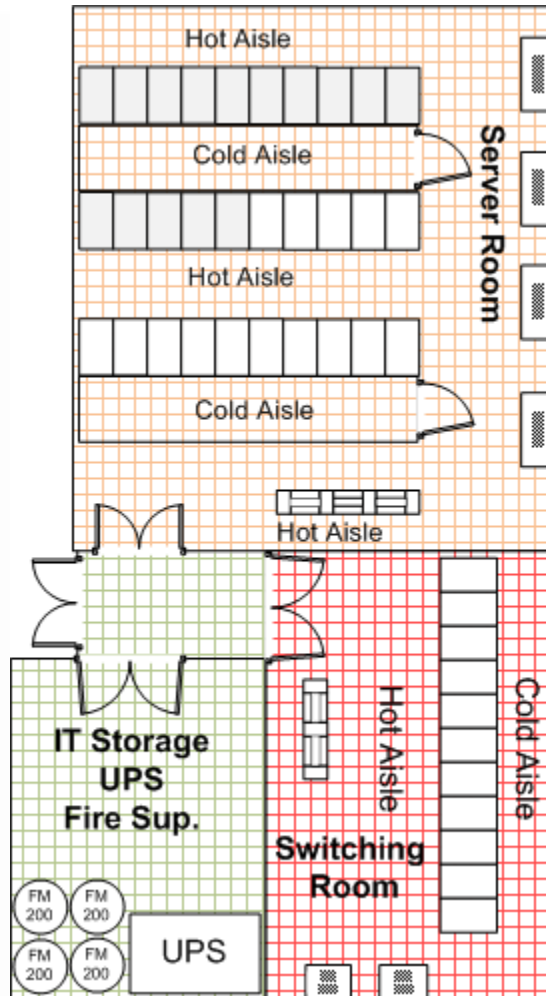

- ✓ Segregate Servers & Core Switches
- ✓ Restricted access
- ✓ Lights-Out
- ✓ KVM
- ✓ Intelligent PDU
- ✓ Edge switches, WAN, Voice Server and Horizontal cable termination in separate room (general access).

InstaPATCH Plus Trunk Cables



Pre-terminated trunk cables in custom lengths with LazrSPEED 150/300 or TeraSPEED fiber in 12 fiber increments (12, 24, 48, 72, 96 and 144)

Higher fiber counts improve the speed of installation

Pulling eye option available to aid in placement

NEW Ruggedized Fanouts are equipped with MPO connectors on one end your connector of choice on the other – for use with our MPO Only Modules

Move from Serial to Parallel - Simple/Fast

Serial

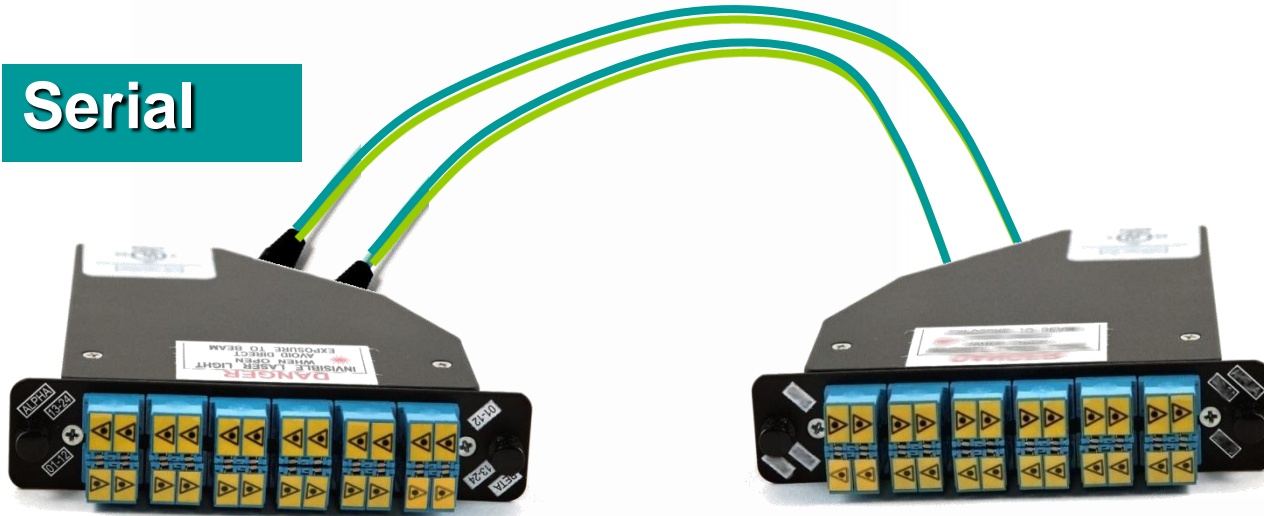

Parallel

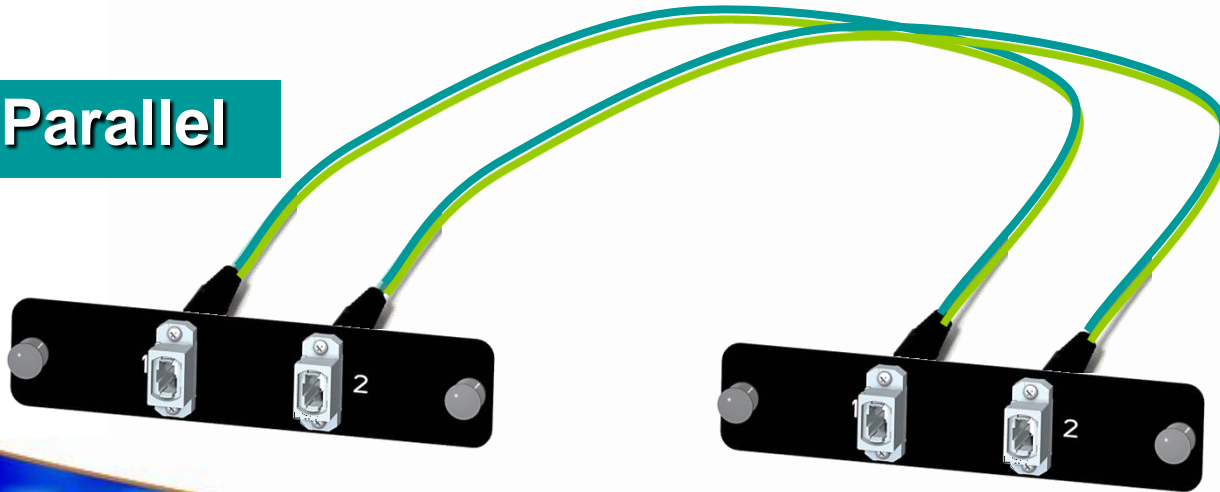

Step 1 - Replace modules with MPO panels

Step 2 - Complete circuit with MPO patch cords

Preserves Your Investment

Reuses trunks

Reuses panels

Reuses racks

No re-termination

Reversible

Pre-terminated Copper



SwitchPack (6x2)

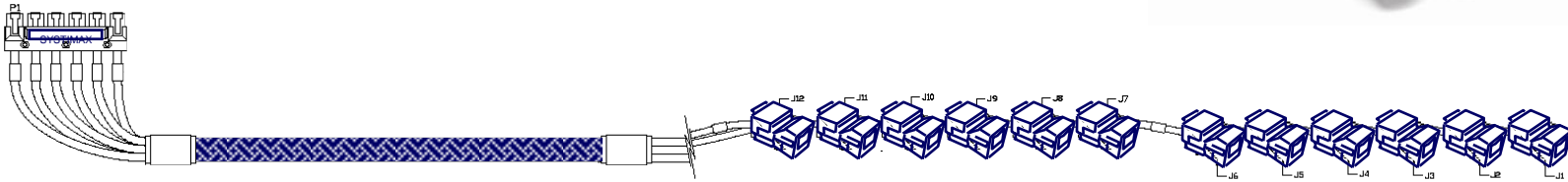

M-s OutletSerie



1100 Module or PatchMAX Module



SwitchPack

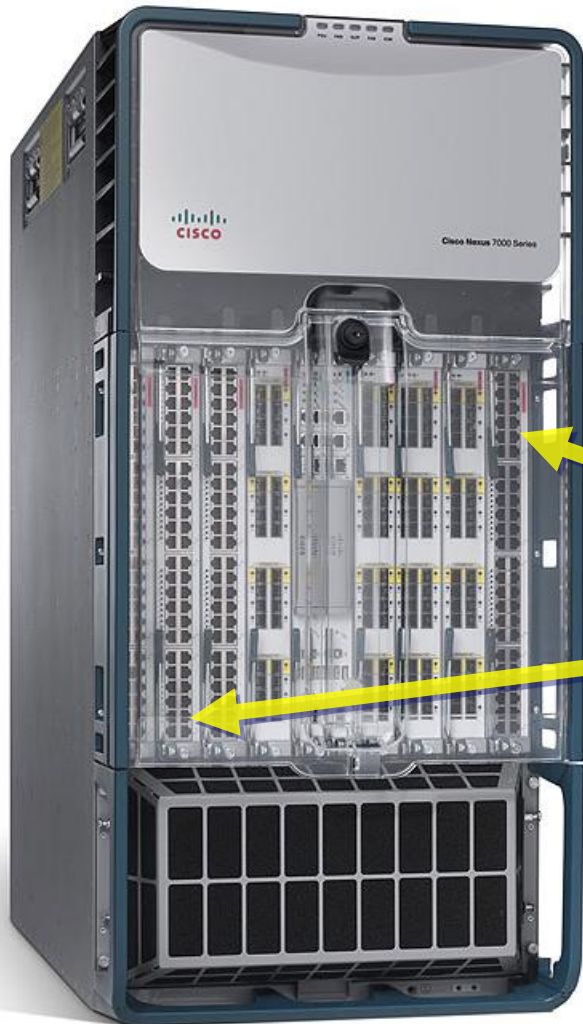

SwitchPack12 (6x2)

6x2



Good News – Standards Exist (cabling)

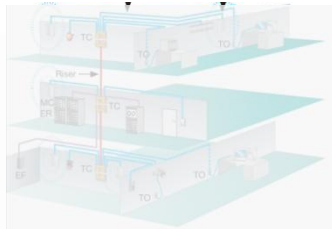

Enterprise
Cabling



Data Centre
Cabling



EN 50173-1:

Information technology Generic cabling systems - Part 1: General requirements

EN 50173-5:

Information Technology –Generic Cabling Systems - Part 5: Data Centres

TIA 568B:

Commercial Building Telecommunication Cabling Standard

TIA/EIA-942:

Telecommunications Infrastructure Standard for Data Centres

ISO/IEC 11801:

Information technology – Generic cabling for customer premises

Draft ISO/IEC 24764:

Generic cabling for data-centres



Infrastructure Standards - Data Centres



Media	TIA/EIA-942	EN 50173-5	ISO 24764
Published	2005	2007	2008?
Copper	Cat 6 recommended	Minimum Class E	Class E _A
Fibre	OM3 recommended OS1	OM3 recommended OS1	OM3 recommended OS2
Connector		SFF (1-2 Fibers) MPO (> 2 fibres)	LC (1-2 Fibers) MPO (> 2 fibres)

- **Data Centre efficiency requires holistic design**
- **Data infrastructure critical to overall efficiency**
- **Enclosure of Cold Aisle, in existing Data Centres can dramatically reduce cooling costs.**
- **Next Generation Cabinets should be considered for new installs.**
- **Converged Networks Demand Design Rethink.**

Thank you!

Kedington

..... The KEY network element